

Dorvic

Multi-roller Skates

THE UK'S PRINCIPAL SKATE AND ROLLER MANUFACTURERS

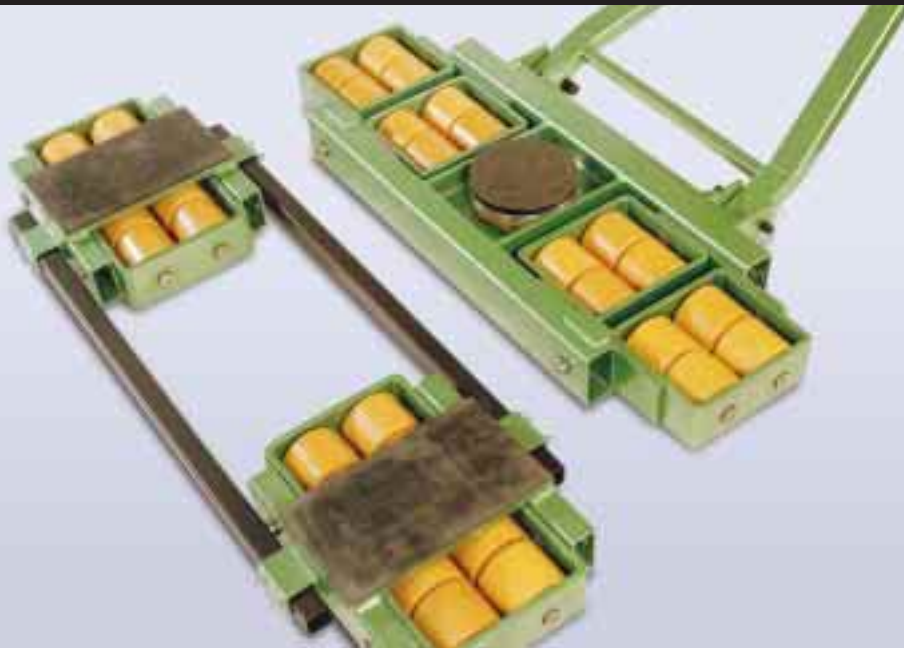

Model: DB7

Set capacity 80,000kgs
(Illustrated)

Supplied with polyurethane wheels only

Dorvic multi-roller skates provide a comprehensive modular load moving system designed to safely cope with moving heavy weights.

- Polyurethane wheels for use on sensitive floors e.g. highly painted, tiled surfaces.
- All wheels have shielded ball bearings for low rolling resistance.
- No floor damage.
- Steerable front skates for total control.
- Steering handle with towing eye.
- Even weight distribution.
- Modular format for three or four point moving.
- Non-slip neoprene pads on each load bearing surface.
- Low weight and compact size for easy transportation.
- Combinations provide easy configurations.
- Manufactured to the highest specifications by Dorvic, The U.K.'s No.1 manufacturer of heavy load moving skates since 1967.

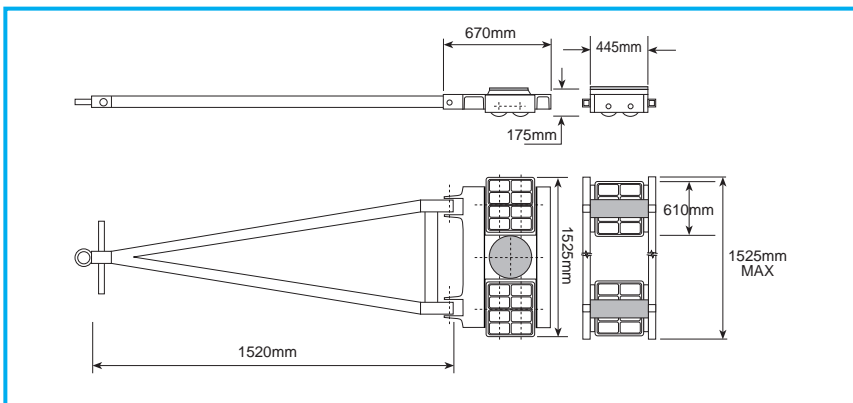

Steerable Turntable Skate			Adjustable Rear Skates		
Model Ref	Polyurethane	DB7/STS/P	Model Ref	Polyurethane	DB7/ARS/P
Capacity		40,000kgs	Capacity (pair)		40,000kgs
Overall height		175mm	Overall height		175mm
Overall width		1525mm	Adjustable width		To 1500mm Max
Turntable dia		253mm	Load surfaces		260mm x 445mm
Wheels	16 No.	140mm dia x 120mm	Wheels	16 No.	140mm dia x 120mm
Handle length		1520mm	Weight (each skate)		142kgs
Weight (inc. handle)		298kgs			
Weight of total set 588kgs					



Dorvic Skates, New Street,
Halfway, Sheffield, S20 3GH, UK.

© Dorvic Skates 2003. All rights reserved
All dimensions and weights are approximate.
We reserve the right to alter or amend designs
and materials specifications without notice.

Tel: +44 (0) 114 248 5633 E-mail: sales@dorvic.com
Fax: +44 (0) 114 251 0654 Web: www.dorvic.com