

# Dorvic

## Multi-roller Skates

**THE UK'S PRINCIPAL SKATE AND ROLLER MANUFACTURERS**

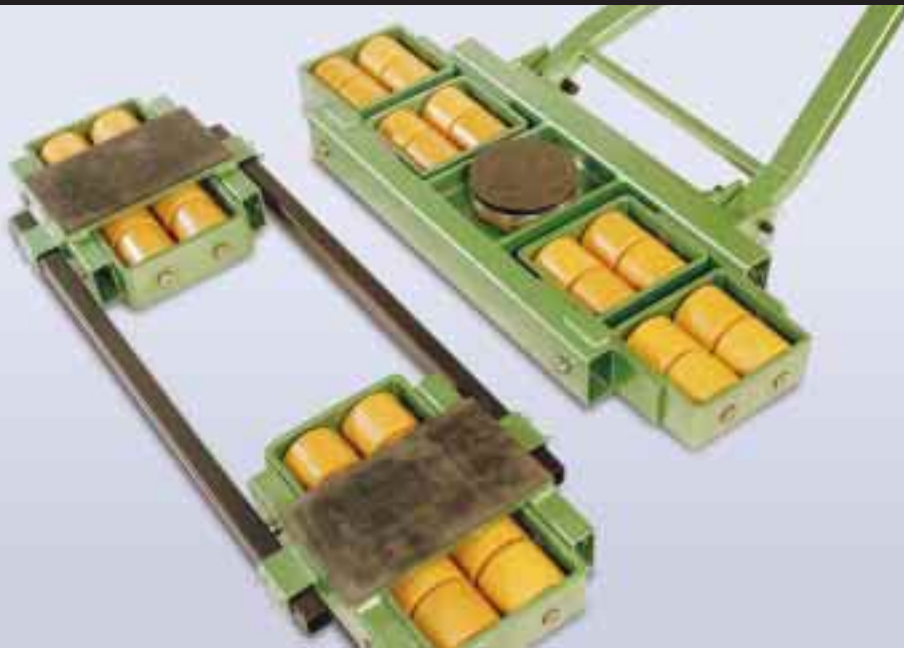

### Model: DB6

Set capacity 60,000kgs

Supplied with polyurethane wheels only.

Dorvic multi-roller skates provide a comprehensive modular load moving system designed to safely cope with moving heavy weights.

- Polyurethane wheels for use on good surfaces, particularly sensitive floors e.g. highly painted, tiled surfaces.
- All wheels have shielded ball bearings for low rolling resistance.
- No floor damage.
- Steerable front skates for total control.
- Steering handle with towing eye.
- Even weight distribution.
- Modular format for three or four point moving.
- Non-slip neoprene pads on each load bearing surface.
- Low weight and compact size for easy transportation.
- Combinations provide easy configurations.
- Manufactured to the highest specifications by Dorvic, The U.K's No.1 manufacturer of heavy load moving skates since 1967.

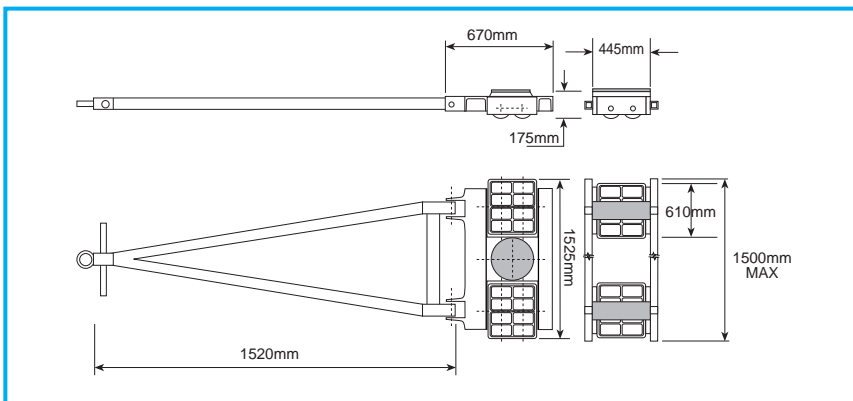

Steerable Turntable Skate			Adjustable Rear Skates		
Model Ref	Polyurethane	DB6/STS/P	Model Ref	Polyurethane	DB6/ARS/P
Capacity		30,000kgs	Capacity (pair)		30,000kgs
Overall height		175mm	Overall height		175mm
Overall width		1525mm	Adjustable width		To 1500mm Max
Turntable dia		253mm	Load surfaces		260mm x 445mm
Wheels	16 No.	140mm dia x 120mm	Wheels	16 No.	140mm dia x 120mm
Handle length		1520mm	Weight (each skate)		138kgs
Weight (inc. handle)		290kgs			
Weight of total set 572kgs					

CE © Dorvic Skates 2003. All rights reserved  
 All dimensions and weights are approximate.  
 We reserve the right to alter or amend designs  
 and materials specifications without notice.



Dorvic Skates, New Street,  
 Halfway, Sheffield, S20 3GH, UK.

Tel: +44 (0) 114 248 5633 E-mail: sales@dorvic.com  
 Fax: +44 (0) 114 251 0654 Web: www.dorvic.com