

Dorvic

Multi-roller Skates

THE UK'S PRINCIPAL SKATE AND ROLLER MANUFACTURERS

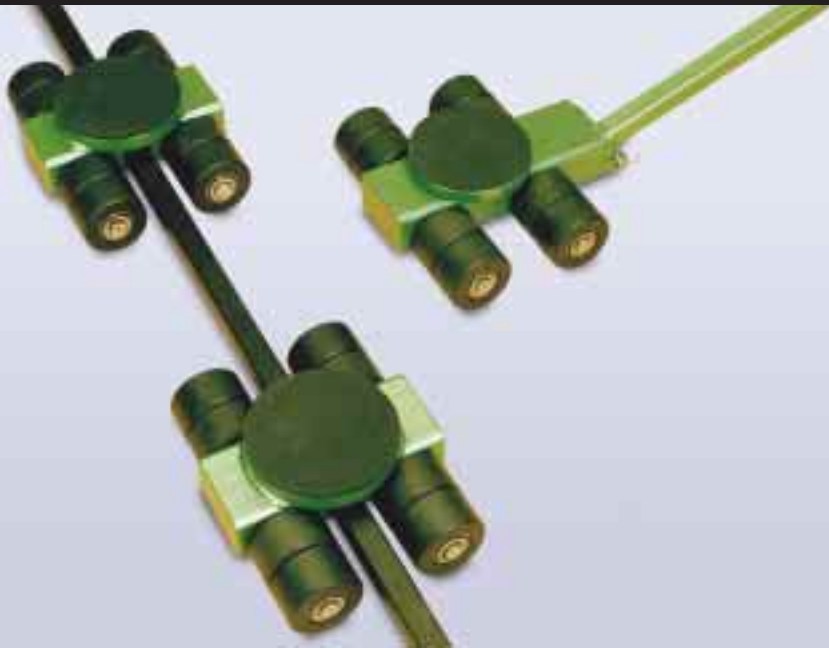

Model: DB2

Set capacity (nylon wheels) 9,000kgs
(Illustrated)

Set capacity (polyurethane wheels) 6,000kgs

Dorvic multi-roller skates provide a comprehensive modular load moving system designed to safely cope with moving heavy weights.

- Supplied with either nylon or polyurethane wheels as standard. Steel wheels available by request.
- Nylon wheels for use on good to average floor surfaces.
- Polyurethane wheels for use on sensitive floors e.g. highly painted, tiled surfaces.
- All wheels have shielded ball bearings for low rolling resistance.
- No floor damage.
- Steerable front skates for total control.
- Even weight distribution.
- Modular format for three or four point moving.
- Non-slip neoprene pads on each load bearing surface.
- Low weight and compact size for easy transportation.
- Combinations provide easy configurations.
- Manufactured to the highest specifications by Dorvic, The U.K's No.1 manufacturer of heavy load moving skates since 1967.

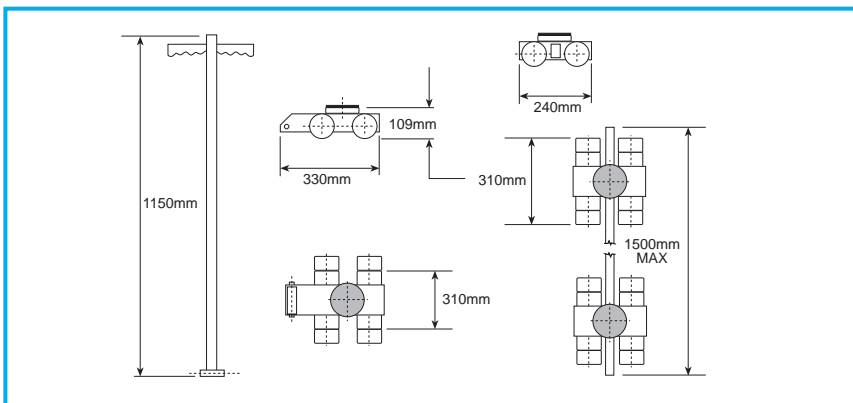

Steerable Turntable Skate			Adjustable Rear Skates		
Model Ref	Nylon Polyurethane	DB2/STS/N DB2/STS/P	Model Ref	Nylon Polyurethane	DB2/ARS/N DB2/ARS/P
Capacity	Nylon Polyurethane	4,500kgs 3,000kgs	Capacity (pair)	Nylon Polyurethane	4,500kgs 3,000kgs
Overall height	109mm		Overall height	109mm	
Overall width	310mm		Adjustable width	To 1500mm Max	
Turntable dia	160mm		Load surfaces	2 No. 160mm dia	
Wheels	8 No. 82mm dia x 48mm		Wheels	16 No. 82mm dia x 48mm	
Handle length	1150mm				
Weight (inc. handle)	16kgs		Weight (each skate)	12.5kgs	
Weight of total set 44kgs					



Dorvic Skates, New Street,
Halfway, Sheffield, S20 3GH, UK.

© Dorvic Skates 2003. All rights reserved
All dimensions and weights are approximate.
We reserve the right to alter or amend designs
and materials specifications without notice.

Tel: +44 (0) 114 248 5633 E-mail: sales@dorvic.com
Fax: +44 (0) 114 251 0654 Web: www.dorvic.com